

Temposonics®

Magnetostrictive Position Sensors



G-Series Linear Position Sensor
Analog and Digital Pulse Outputs

550959 D

Product Specification

Temposonics Model GH

Temposonics Model GP



- Temposonics next generation platform optimized for performance, durability and functionality
- Advanced sensor communication via serial RS-422, RS-485 or Infrared interfaces
- Enhanced diagnostics and programming capability using serial communications and visual LEDs
- Designed for backwards compatibility with legacy Temposonics products

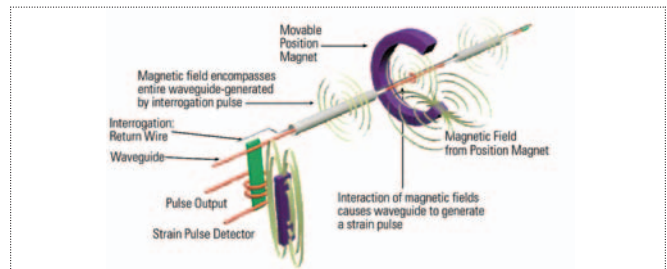

The Benefits of Magnetostrictive Sensing

Temposonics linear sensors use the time-based magnetostrictive position sensing principle developed by MTS. Within the sensing element, a sonic strain pulse is induced in a specially-designed magnetostrictive waveguide by the momentary interaction of two magnetic fields. One field comes from a movable permanent magnet that passes along the outside of the sensor. The other field comes from an “interrogation” current pulse applied along the waveguide. The resulting strain pulse travels at ultrasonic speed along the waveguide and is detected

at the head of the sensing element. The position of the magnet is determined with high precision and speed by accurately measuring the elapsed time between the application of the interrogation pulse and the arrival of the resulting strain pulse with a high speed counter. Using the elapsed time to determine position of the permanent magnet provides an absolute position reading that never needs recalibration or re-homing after a power loss. Non-contact sensing eliminates wear, and guarantees the best durability and output repeatability.



All specifications are subject to change. Please contact MTS for specifications that are critical to your needs. Refer to “How To Order” on page 7 or go to www.temposonics.com for the latest list of G-Series support documentation.

The next generation Temposonics

MTS Sensors, the inventors of magnetostrictive position sensing and makers of Temposonics sensors, is proud to introduce our new G-Series linear position sensors utilizing our next generation technology platform. G-Series position sensors feature a microprocessor-based design with enhanced diagnostics and programmability to maximize backwards compatibility.

Backwards compatibility is one of the primary benefits of the new G-Series position sensor. G-Series position sensors provide the same functionality as Tempo II and L-Series sensors making them an ideal direct replacement for these products.

In addition to providing advanced programming and diagnostic capabilities in a rugged package, G-Series position sensors also include the following features:

- Electronics housing small enough to allow for drop in replacements of legacy Temposonics products.
- Standard 24 Vdc and extended input power supply options for compatibility with older controller interfaces.
- Fully adjustable voltage and current outputs within:
 - 10 to +10 Vdc or +10 to -10 Vdc
 - 0 to 20 mA or 20 to 0 mA
- All outputs are available up to 300 in. stroke length (hydraulic-rod style)
- Up to 15 magnet positions simultaneously using the Start/Stop output option.
- Integral connector replacement options including:
 - Hanging (inline) connectors
 - Adapter cables
 - Field-installed connector kits

Parameter	Specification
Measured variable:	Displacement
Resolution:	<i>Analog:</i> Infinite <i>Digital:</i> $1 \div [\text{gradient} \times \text{crystal freq. (MHz)} \times \text{circulation}]$
Non-linearity:	$\pm 0.02\%$ or $\pm 0.05 \text{ mm}$ ($\pm 0.002 \text{ in.}$), whichever is greater
Repeatability:	$\pm 0.001\%$ of full stroke or $\pm 0.0001 \text{ in.}$ ($\pm 0.0025 \text{ mm}$), whichever is greater.
Outputs:	<i>Analog:</i> Voltage or current <i>Digital:</i> Start/Stop or PWM
Measuring range:	Hydraulic-rod style: <i>Analog:</i> 50 to 2540 mm (2 to 100 in.)* <i>Digital:</i> 50 to 7620 mm (2 to 300 in.) Profile style: <i>Analog:</i> 50 to 2540 mm (2 to 100 in.)* <i>Digital:</i> 50 to 5080 mm (2 to 200 in.)
Operating voltage:	+24 Vdc nominal (20.4 - 28.8 Vdc) standard +9 to +28.8 Vdc optional
Operating temperature:	- 40 to +80 °C, (85 °C max.**) - 40 to +176 °F (185 °F max.**)
EMC test:	Emissions IEC/EN 61000-6-3, Immunity IEC/EN 61000-6-2, IEC/EN 61000-4-2/3/4/5/6/8, level 3/4 criterion A, CE qualified
Shock rating:	100 g (single hit)/IEC standard 68-2-27 (survivability)
Vibration rating:	5 g/10-2000 Hz/IEC standard 68-2-6
Adjustability:	Field adjustable null and span (for analog sensors only)
Update time:	<i>Analog:</i> < 1 ms (typical) <i>Digital (external interrogate):</i> Minimum = (2.5 + null + stroke) x 10.0 $\mu\text{s/in.}$ x (number of recirculations)

PROFILE STYLE (GP MODEL)

Electronic head:	Aluminum housing
Sealing:	IP 67
Sensor extrusion:	Aluminum (Temposonics profile style)
Mounting:	Adjustable mounting feet or T-slot M5 nut in base channel
Magnet type:	Captive-sliding magnet or floating magnet

ROD STYLE (GH MODEL)

Electronic head:	Aluminum housing
Sealing:	IP 67
Sensor rod:	304L Stainless steel
Operating pressure:	350 bar static, 690 bar spike (5000 psi static; 10,000 psi spike)
Mounting:	Threaded flange M18 x 1.5 or 3/4-16 UNF-3A
Typical mounting torque:	45 N-m (33 ft. - lbs.)
Magnet type:	Ring or floating magnet

* Stroke lengths longer than 2540 mm (100 in.) for analog output are available on a custom basis.

** Consult factory for high temperature applications.

The above specifications for analog output sensors are based on the assumption that output ripple is averaged by the measuring device as with any typical analog device.

Digital-pulse outputs

Temposonics G-Series position sensors provide direct Start/Stop and PWM signals. Standard resolution is 0.004 in. with digital pulse outputs (when using a 28 MHz counter). Higher resolutions are possible with increased circulations or with the use of higher resolution counters.

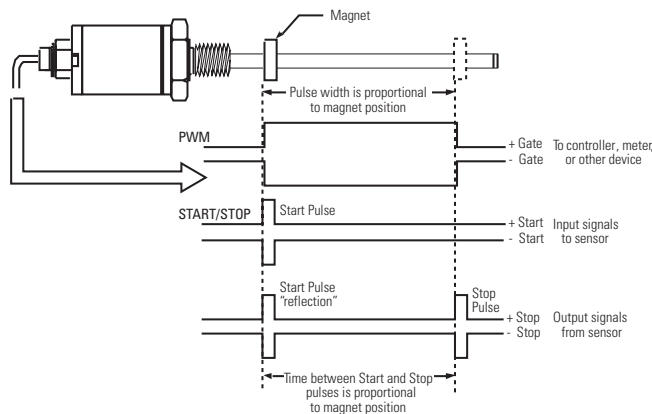

Analog outputs

Temposonics G-Series position sensors with analog outputs provide direct signals, including voltage (0 to 10 Vdc or -10 to +10 Vdc, forward or reverse acting) and current (4 to 20 mA, or 0 to 20 mA, forward or reverse acting). Both voltage and current outputs allow full adjustments of null and span setpoints, (minimum 2 in. between setpoints). Since the outputs are direct, no signal-conditioning electronics are needed when interfacing with controllers or meters.

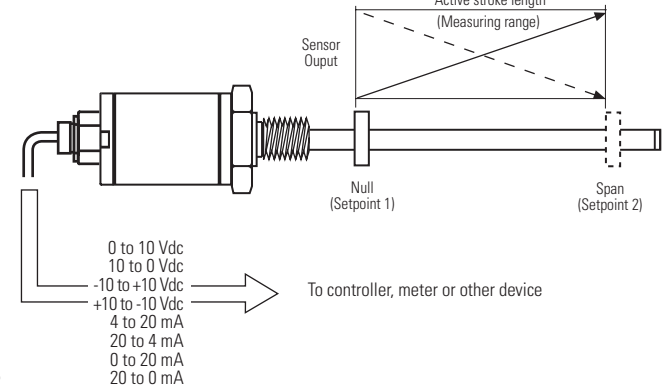

Advanced Communication and Programmability

Temposonics G-Series sensors are preconfigured at the factory by model code designation. For many applications no adjustments are required for normal sensor installation and operation. If, however, sensor parameter changes are desired while in the field, the G-Series sensor is easily programmed.

Using external communication for monitoring and programming, there is no need to open the sensor's electronics housing. This can simplify installation and commissioning, saving valuable time. Keeping the sensor electronics isolated ensures that seal integrity and the highest product reliability are maintained.

The new platform technology inside the G-Series position sensor enables:

- Infrared (IR) send and receive for wireless communication.
- Built-in serial interfaces for robust hard-wired serial communication, (RS-422 for digital-pulse outputs and RS-485 for analog outputs).
- Remote programmability for operational modes and sensor parameters.
- Enhanced monitoring and diagnostic capabilities (see below).

Programmable modes and sensor parameters for G-Series position sensors include:

For Digital-Pulse outputs

- Start/Stop or PWM output mode
- Internal or external interrogation mode for PWM mode
- Number of recirculations (1 to 15) for PWM mode

For Analog outputs

- Voltage or Current output mode
- Voltage or Current output range
- Full adjustment for null and span setpoints

G-Series PC configuration & diagnostics software user interface

G-Series sensor information

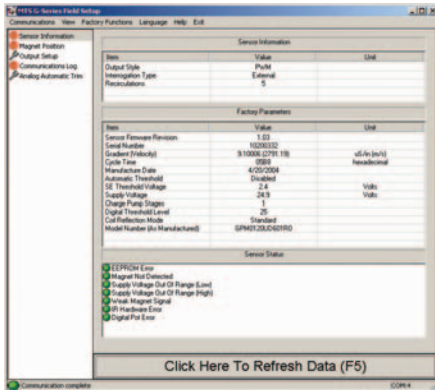

G-Series output setup

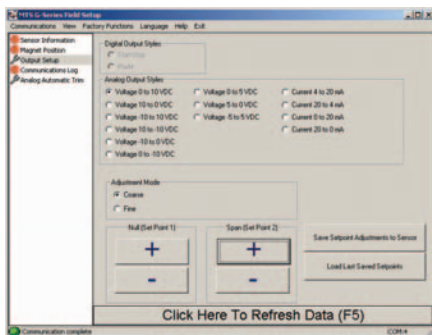

Enhanced Monitoring and Diagnostics

The G-Series simple visual user interface helps resolve the majority of customer installation and troubleshooting issues. Integrated LEDs indicate (refer to LED indicator table):

- Normal operating conditions
- Error conditions, power and sensor/control interface issues
- Programming modes (IR or hard wired)

Hard-wired G-Series serial communication enables diagnostic feedback at a convenient remote location. Access to internal sensor conditions minimizes troubleshooting efforts and enables the development of more sophisticated controller diagnostic routines. All of these features will simplify sensor installation and maximize operational productivity.

G-Series LED indicator table

Green	Red	Description
OFF	OFF	No power to sensor
OFF	ON	Self-diagnostic error
OFF	FLASHING	IR programming mode
ON	OFF	Normal sensor function
ON	ON	Magnet not detected
ON	FLASHING	Missing (external) interrogation
FLASHING	OFF	Serial programming mode
FLASHING	ON	Magnet signal weak
FLASHING	FLASHING	Power out of range (high or low)

G-Series electronics housing with built-in LEDs



G-Series IR Setpoint Programmer
(for Analog output sensors)
Part number 380078

G-Series Analog Handheld
Programmer Part number 253294



Model GH rod-style sensor

The Temposonics G-Series rod-style sensor (Model GH) offers modular construction, flexible mounting configurations, and easy installation. It is designed for internal mounting in applications where high pressure conditions exist, (5000 psi continuous, 10,000 psi spike), such as hydraulic cylinders. The Model GH sensor may also be mounted externally in many applications.

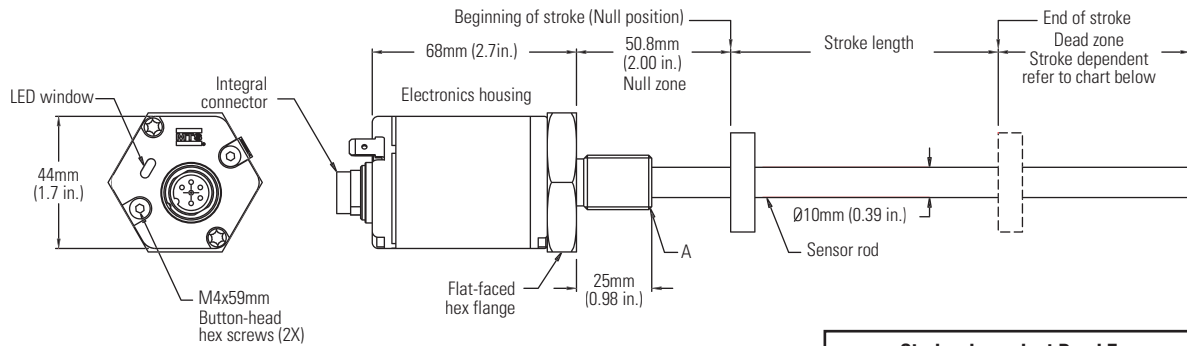

Stroke-dependent Dead Zones	
Stroke length	Dead zone
50 - 5000 mm (2 - 197 in.)	63.5 mm (2.5 in.)
5005 - 7620 mm (197.1 - 300 in.)	66 mm (2.6 in.)

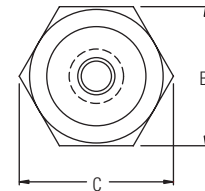
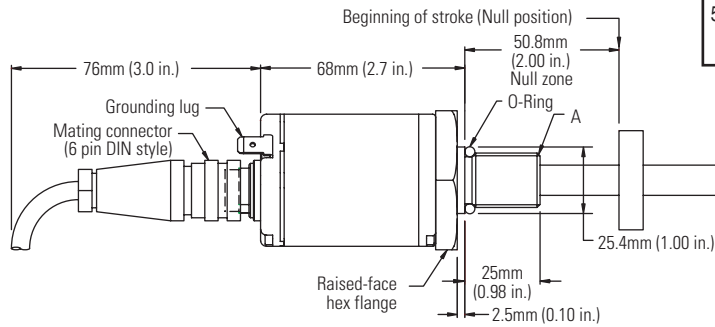

Housing style Flange type	Description	A Flange threads	B Dimensions	C Dimensions
T	US customary threads with raised-face hex	3/4"-16 UNF-3A	44.5 mm (1.75 in.)	51 mm (2.0 in.)
S	US customary threads with flat-faced hex	3/4"-16 UNF-3A	44.5 mm (1.75 in.)	51 mm (2.0 in.)
M	Metric threads with flat-faced hex	M18 x 1.5	46 mm (1.81 in.)	53 mm (2.1 in.)

Cylinder installation

When used for hydraulic cylinders, the sensor's high pressure, stainless-steel rod installs into a 1/2 in. bore in the piston head/rod assembly as illustrated.

The Model GH sensor cartridge can be removed from the flange and rod housing while still installed in the cylinder. This procedure allows quick and easy sensor cartridge replacement, without the loss of hydraulic pressure.

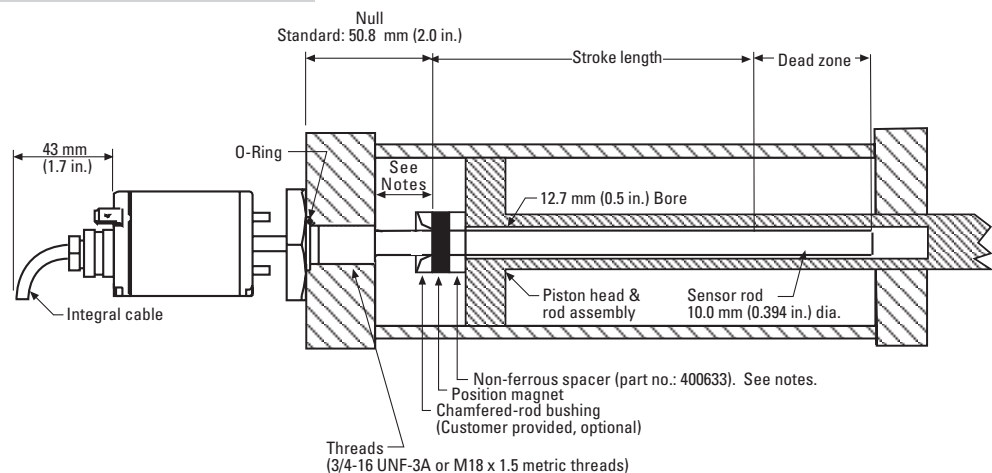

Notes:

- The position magnet requires minimum distances away from ferrous metals to allow proper sensor output. The minimum distance from the front of the magnet to the cylinder end cap is 15 mm, (0.6 in.). The minimum distance from the back of the magnet to the piston head is provided by the non-ferrous spacer, i.e. 3.2 mm, (0.125 in.).
- The illustration above represents a typical installation. Some installation requirements may be application specific.

Model GP profile-style sensor

Temposonics Model GP profile-style sensors offer modular construction, flexible mounting configurations, and easy installation. A choice of two magnet configurations are available with the profile housing: captive-sliding magnet or floating magnet.

Note:

Temposonics Model GP sensors include two mounting feet (part no. 400802) for sensors up to 1250 mm (50 in.). One additional mounting foot is included for every additional 500 mm (20 in.).

Captive-sliding magnet

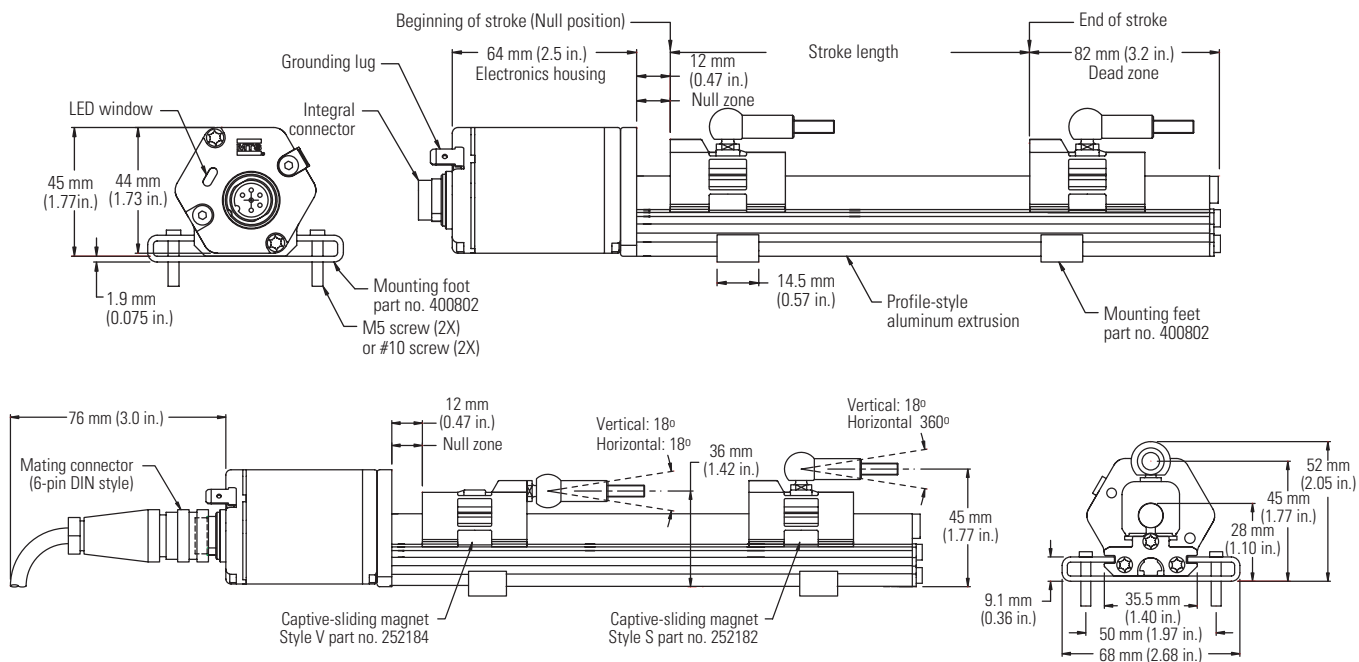

Floating magnet (Open Ring)

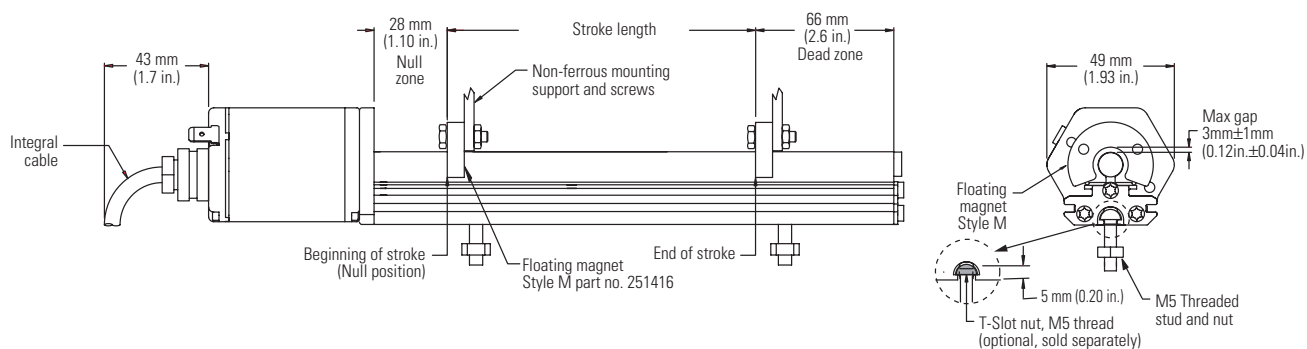

Wiring and Magnets

Sensor integral connector (D60 Male)

Pinout/wire color code (integral or extension cable)

Pin no.	Wire color	Function	Function
		Digital-pulse outputs	Analog outputs
1	Gray	(-) Gate for PWM (-) Stop for Start/Stop or Programming (RS-422 TX-)	0 to 10, -10 to +10 Vdc or 4 to 20 mA, 0 to 20 mA or reverse acting: 10 to 0, 10 to -10 Vdc or 20 to 4 mA, 20 to 0 mA
2	Pink	(+) Gate for PWM (+) Stop for Start/Stop or Programming for (RS-422 TX+)	Return for pin 1
3	Yellow	(+) Interrogation for PWM (+) Start for Start/Stop or Programming (RS-422 RX+)	Programming (RS-485+)
4	Green	(-) Interrogation for PWM (-) Start for Start/Stop or Programming (RS-422 RX-)	Programming (RS-485-)
5	Red or Brown	Supply voltage (+Vdc)	Supply voltage (+Vdc)
6	White	DC Ground (for supply)	DC Ground (for supply)

Integral D6 connector (male) as viewed from end of sensor

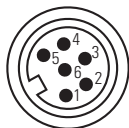

Notes:

- A grounding lug on the end of the sensor is provided for convenient connection to earth ground.
- Appropriate grounding of cable shield is required at the controller end.

Magnets

Magnets must be ordered separately with Model GH position sensors. The standard ring magnet (part no. 201542-2) is suitable for most applications.

Magnets are included when you order the Model GP position sensor. The sensor can be configured with one of two magnet configurations: captive-sliding or floating magnet (open ring).

Captive-sliding magnet, style V part no. 252184

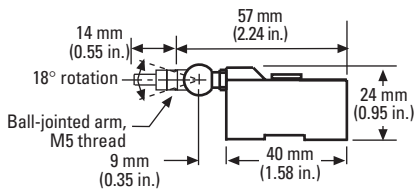

Captive-sliding magnet, style S part no. 252182

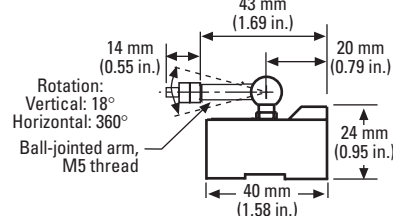

Floating magnet (open ring), style M (may be used with models GH and GP sensors) part no. 251416-2

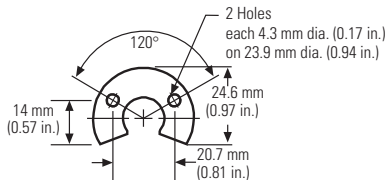

ID: 13.5 mm (0.53 in.)
OD: 32.8 mm (1.29 in.)
Thickness: 7.9 mm (0.312 in.)

Ring magnet part no. 400533



ID: 13.5 mm (0.53 in.)
O.D.: 25.4 mm (1.0 in.)
Thickness: 7.9 mm (0.312 in.)

Magnet float (level sensing applications) part no. 251447

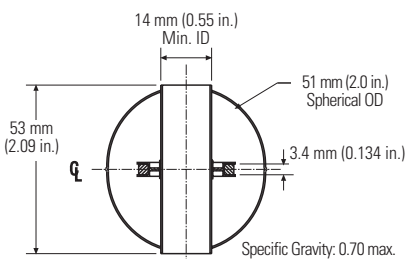

Specific Gravity: 0.70 max.
Pressure: 870 psi max.
(Float for use with rod-style sensors in hydraulic fluid or fresh water applications only)

Standard-ring magnet part no. 201542-2

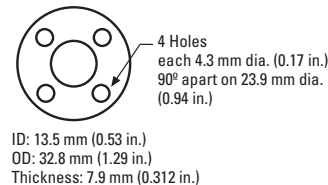

ID: 13.5 mm (0.53 in.)
OD: 32.8 mm (1.29 in.)
Thickness: 7.9 mm (0.312 in.)

Magnet spacer (non-ferrous spacer for use with standard ring magnet) part no. 400633

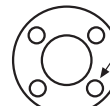

ID: 14.3 mm (0.56 in.)
O.D.: 31.8 mm (1.25 in.)
Thickness: 3.2 mm (0.125 in.)

Cable connectors (field-installed D6 female) Mates with sensor's integral connector

D6 Straight-exit connector part no. 560700

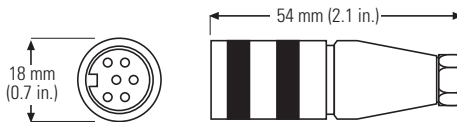

D6 90° connector part no. 560778

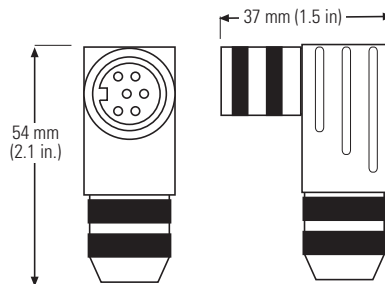

How To Order

Position sensor

When placing an order, build the desired model number using the model number guide (right). A wide range of G-Series position sensor configurations are available to meet the demands of your particular application.

If you have any questions about how to apply G-Series position sensors, please contact MTS Applications Engineering or your local MTS distributor. Both of these resources are available to assist you in designing an effective position sensing system to fit your application.

Notes:

- Refer to *G-Series Cross Reference* part numbers 550967 and 550956 for information about backwards compatible replacement options, including integral cables with in-line connectors, adapter cables, and field-installed connector kits. Contact the factory for specials.
- Refer to the *G-Series User's Manual*, part no. 550966 for initial setup information.
- Refer to *G-Series installation drawings*, part no's. 550953 and 550955 for installation information.

2 or 3 digit code depending on output selected

G														
1	2	3	4	5	6	7	8	9	10	11	12	13	14	15

SENSOR MODEL

GH = Hydraulic rod style
GP = Profile style

HOUSING STYLE

Temposonics model GH only (magnet must be ordered separately):

T = US customary threads, raised-faced hex, and pressure tube
S = US customary threads, flat-faced hex, and pressure tube
M = Metric threads, flat-faced hex, and pressure tube
B = Sensor cartridge only (No application housing, stroke lengths 1 to 72 in.)

Temposonics model GP only (magnet included):

M = Floating magnet (Open ring, part no. 251416-2)
S = Captive-sliding magnet with joint at top (part no. 252182)
V = Captive-sliding magnet with joint at front (part no. 252184)

STROKE LENGTH

--- U = Inches and tenths (Encode in 0.2 in. increments)
--- M = Millimeters (Encode in 5 mm increments)

CONNECTION TYPE

Integral connector

D60 = 6-pin DIN, standard

Integral cables

R = Integral cable, PVC jacket, pigtail termination.

Cable Length

--- = Encode in feet if using US customary stroke length, encode in meters if using metric stroke length
Range = 1 (01) to 99 (99) ft. or 1 (01) to 30 (30) meters

INPUT VOLTAGE

1 = +24 Vdc (+20%, -15%), standard
2 = +9 to +28.8 Vdc.

OUTPUT

Voltage

V0 = 0 to +10 Vdc
V1 = +10 to 0 Vdc
V2 = -10 to +10 Vdc
V3 = +10 to -10 Vdc

Current

A0 = 4 to 20 mA
A1 = 20 to 4 mA
A2 = 0 to 20 mA
A3 = 20 to 0 mA

Digital pulse

RO = Start/Stop. If more than one magnet, the _ denotes number of magnets in hexadecimal (refer to Table C)
D_ = Pulse-Width Modulated (PWM) (Fill in the two blanks with the following codes.)
a b

Stroke length notes:

- GH Voltage or Current = 2-100 in. (50-2540 mm).
- GH Digital Pulse = 2-300 in. (50-7620 mm).
- GP Voltage or Current = 2-100 in. (50-2540 mm).
- GP Digital Pulse = 2-200 in. (50-5080 mm).

Cable length notes:

- MTS recommends the maximum integral cable length to be 10 meters or 33 feet.
- Cables greater than 10 meters in length are available, however, proper care must be taken during handling and installation.

L-Series retrofit note:

- For stroke lengths < or = to 60 in., either +15 volts or +24 volts could be used for L-Series. Choose the appropriate G-Series option based on the power supply used. Choose option 2 if not certain.
- For stroke lengths > 60 in., select G-Series option 1.

Table A:

Circulation Count vs. Resolution for PWM Output (Based on 28 MHz counter)

Resolution	Circulation Count*
0.00026 in. (0.0066mm)	15
0.0005 in. (0.0127 mm)	8
0.001 in. (0.025 mm)	4
0.002 in. (0.051 mm)	2
0.004 in. (0.102 mm)	1

*Limited by stroke length for sensors configured for internal interrogation. (Refer to Table B.)

Table B:

Maximum Circulation Count vs Stroke for PWM Output w/Internal Interrogation

Resolution	Maximum Circulation Count
≤ 84 in. (2134 mm)	15
> 84 in. (2134 mm)	1

Table C:

Decimal:	1	2	3	4	5	6	7	
Hexadecimal:	1	2	3	4	5	6	7	
Decimal:	8	9	10	11	12	13	14	15
Hexadecimal:	8	9	A	B	C	D	E	F

Extension cable with connectors for the D6, (D60), connection type (uses standard type cable)

D														
----------	--	--	--	--	--	--	--	--	--	--	--	--	--	--

SENSORS CONNECTION TYPE

D6 = Female connector (straight-exit) for sensors with D6 (D60) connector
DA = Female connector (90° exit) for sensors with D6 (D60) connector

CABLE LENGTHS

For standard length cables up to 100 ft.

005 = 5 ft. 050 = 50 ft.
015 = 15 ft. 100 = 100 ft.
025 = 25 ft.

For custom length cables over 100 ft.

--- = Cable length (maximum cable length is dependent on the output selected; consult MTS Applications Engineering.)

CABLE TERMINATION

PO = Pigtail connection
D6M = 6-pin D6 Male connector (straight exit)

How To Order

Accessories

Description	Function/Notes	Part no.
Mounting feet, standard (spares)	Model GP sensors come with mounting feet (see page 5).	400802
Base channel T-slot nut	Nut for mounting model GP sensors. Requires M5 screw (see page 5).	401602
Hex jam nut	3/4-16 UNF Nylon insert locknut for use with model GH sensors with style "T" or "S" housings	500015
Hex jam nut	M18 x 1.5 for use with model GH sensors with style "M" housing	500018
O-Ring (spare)	For use with model GH sensors with style "T" or "S" housings	560315
O-Ring (spare)	For use with model GH sensors with style "M" housing	401133
Joint-rod Sleeve (1 in.)	For use with model GP sensors with "S" or "V" style magnets	401603
Ball-jointed arm, straight	For use with model GP sensors with "S" or "V" style magnets	401913

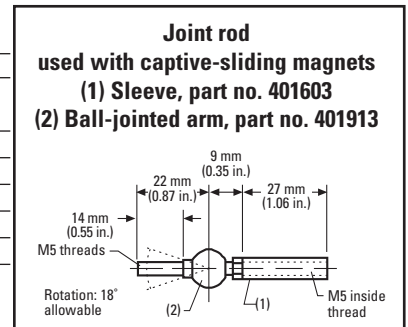

Magnets and float options

Description	Function/Notes	Part no.
Small open ring (model GP spare)	Magnet style M, "floating" magnet used with model GH and GP sensors.	251416-2
Small ring magnet	Standard magnet for model GH sensors.	201542-2
Magnet float	For use with model GH sensors used to measure liquid level.	251447
Captive-sliding magnet (spare)	Style S captive-sliding magnet with joint at top. Comes with GP sensors.	252182
Captive-sliding magnet (spare)	Style V captive-sliding magnet with joint at front. Comes with GP sensors.	252184
Magnet spacer	For use with standard ring magnet, part no. 201542.	400633
Collar	Provides end of stroke "stops" for magnet float, part no. 251447.	560777
Magnet mounting screws	Used to mount the standard ring magnet, part no. 201542. (4 screws required)	560357

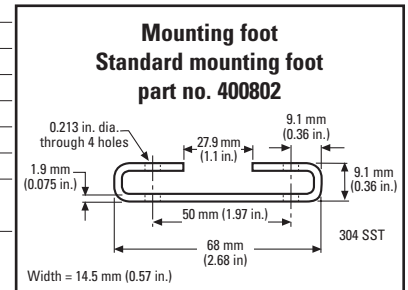

Field-installed connectors

Description	Function/Notes	Part no.
6-Pin DIN connector, straight	Female, straight exit, mates to D60 connection type. See page 6.	560700
6-Pin DIN connector, 90°	Female, 90° exit, mates to D60 connection type. See page 6.	560778

Programming tools

Description	Function/Notes	Part no.
G-Series documentation and software CD	Includes G-Series PC setup software part no. 625060*, G-Series Palm OS software part no. 625061*, G-Series Quick Start part no. 550966 and additional documentation.	550971
Infrared setpoint programmer	For adjusting null (setpoint 1) and span (setpoint 2) on G-Series analog sensors.	380078
RS-485 & RS-422 to RS-232 converter	Provides hardware interface for G-Series PC setup software.	380077

* Download at no charge from website (www.mtssensors.com).

Optional extension rods (for use with captive-sliding magnets)

Extension rod lengths	Part no.	Extension rod lengths	Part no.
60.3 mm (2.375 in.)	401768-2	390.5 mm (15.375 in.)	401768-15
85.7 mm (3.375 in.)	401768-3	466.7 mm (18.375 in.)	401768-18
111.1 mm (4.375 in.)	401768-4	517.5 mm (20.375 in.)	401768-20
161.9 mm (6.375 in.)	401768-6	542.9 mm (21.375 in.)	401768-21
187.3 mm (7.375 in.)	401768-7	619.1 mm (24.375 in.)	401768-24
212.7 mm (8.375 in.)	401768-8	771.5 mm (30.375 in.)	401768-30
238.1 mm (9.375 in.)	401768-9	923.9 mm (36.375 in.)	401768-36
263.5 mm (10.375 in.)	401768-10	1076.3 mm (42.375 in.)	401768-42
314.3 mm (12.375 in.)	401768-12	1228.7 mm (48.375 in.)	401768-48
365.1 mm (14.375 in.)	401768-14	1533.5 mm (60.375 in.)	401768-60

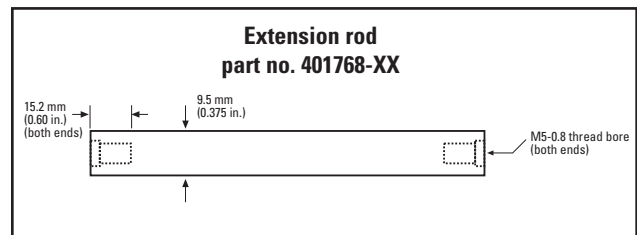

Part Number: 07-05 550959 Revision D

MTS and Temposonics are registered trademarks of MTS Systems Corporation.

All other trademarks are the property of their respective owners.

All Temposonics sensors are covered by US patent number 5,545,984. Additional patents are pending.

Printed in USA. Copyright © 2005 MTS Systems Corporation. All Rights Reserved.



UNITED STATES
MTS Systems Corporation
 Sensors Division
 3001 Sheldon Drive
 Cary, NC 27513
 Tel: 800-633-7609
 Fax: 919-677-0200
 800-498-4442
www.mtssensors.com
sensorsinfo@mts.com

GERMANY
MTS Sensor Technologie
 GmbH & Co. KG
 Auf dem Schüffel 9
 D - 58513 Lüdenscheid
 Tel: +49 / 23 51 / 95 87-0
 Fax: +49 / 23 51 / 56 491
www.mtssensor.de
info@mtssensor.de

JAPAN
MTS Sensors Technology
 Corporation
 Ushikubo Bldg.
 737 Aihara-cho, Machida-shi
 Tokyo 194-0211, Japan
 Tel: + 81 (42) 775 / 3838
 Fax: + 81 (42) 775 / 5512
www.mtssensor.co.jp
info@mtssensor.co.jp