

Temposonics®

Magnetostrictive Linear-Position Sensors

R-Series Model RP and RH Sensors
CANbus Output
(CANopen and CANbasic)

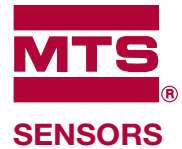

550991 B

Product Specification



- Rugged industrial sensor
- Linear, absolute measurement
- LEDs for sensor diagnostics
- Non-contact sensing technology
- Superior accuracy, resolution up to 2 μm
- Non-linearity less than 0.01%
- Repeatability within 0.001%
- Direct CAN output, displacement + speed
- Multi-magnet position measurement (up to 15 positions per sensor)

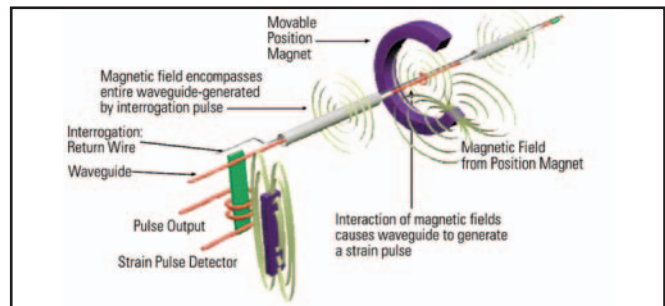
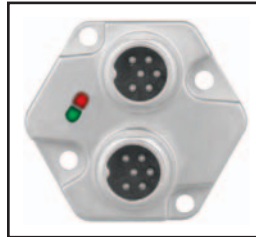

The benefits of magnetostrictive sensing

Temposonics linear sensors use the time-based magnetostrictive position sensing principle developed by MTS. Within the sensing element, a sonic strain pulse is induced in a specially designed magnetostrictive waveguide by the momentary interaction of two magnetic fields. One field comes from a movable permanent magnet that passes along the outside of the sensor. The other field comes from an “interrogation” current pulse applied along the waveguide. The resulting strain pulse travels at ultrasonic speed along the waveguide and is detected at the head of the

sensing element. The position of the magnet is determined with high precision and speed by accurately measuring the elapsed time between the application of the interrogation pulse and the arrival of the resulting strain pulse with a high speed counter. Using the elapsed time to determine position of the permanent magnet provides an absolute position reading that never needs recalibration or re-homing after a power loss. Non-contact sensing eliminates wear, and guarantees the best durability and output repeatability.

R-Series linear-position sensors

- R-Series model RH and RP sensors are extremely robust and are ideal for continuous operation under harsh industrial conditions.
- Two standard sensor housings are available. The rod housing is capable of withstanding high pressures such as those found in hydraulic cylinders. The profile extrusion housing provides convenient mounting options and sliding magnets.
- The sensor head contains the active signal conditioning and a complete integrated electronics interface. Double shielding is used to ensure EMI protection for unsurpassed reliability and operating safety.



All specifications are subject to change. Please contact MTS for specifications that are critical to your needs.

Enhanced monitoring and diagnostics

Sensor status and diagnostic display

Integrated LEDs (green/red) provide basic visual feedback for normal sensor operation and troubleshooting.

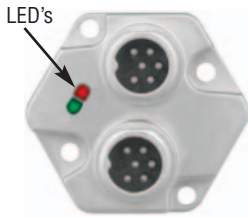

CANbus interface

Green	Red	Description
ON	OFF	Normal function
ON	Flashing	Magnet out of setup range
ON	ON	Magnet not detected
Flashing	ON	Programming mode

CANbus outputs

Temposonics R-Series models RP and RH linear-position sensors, as slave devices, fulfill all requirements of the CANbus (ISO 11898) protocol. The sensor's electronics convert the displacement measurements into bus oriented outputs and transfer this data directly to the controller. The bus interface is appropriate for serial data transfer up to 1Mbps. Sensor integrated software supports bus profiles CANopen, CANbasic and DeviceNet for a comprehensive customized configuration of the sensor-bus system. (Reference separate MTS document for DeviceNet output.)

Operation modes

CANbus sensors provide the following single or multi-magnet measurements:

- Standard measurement:
 - CANbasic; Displacement + speed (using one magnet)
 - CANopen; Displacement + speed (using one to four magnets)
- Multi-magnet measurement:
 - CANbasic; Positions for each of two to fifteen magnets simultaneously

Single magnet sensor

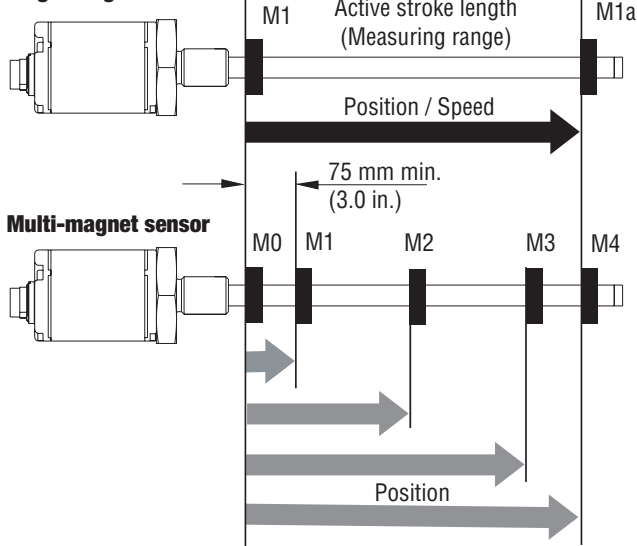

Multi-magnet sensor

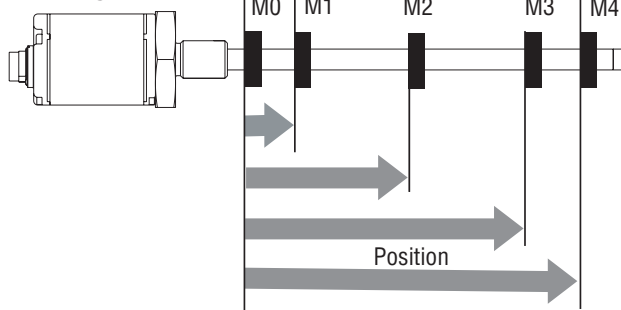

Parameter	Specification												
Measured variable:	Displacement, speed / optional: multi-magnet measurements (up to 15 magnet positions simultaneous)												
Resolution:	CANopen: <table border="1"> <thead> <tr> <th>Displacement</th> <th>Speed</th> </tr> </thead> <tbody> <tr> <td>5 µm</td> <td>0.5 mm/s</td> </tr> <tr> <td>2 µm</td> <td>0.2 mm/s</td> </tr> </tbody> </table> CANbasic: <table border="1"> <thead> <tr> <th>Displacement</th> <th>Speed</th> </tr> </thead> <tbody> <tr> <td>5 µm</td> <td>1.0 mm/s</td> </tr> <tr> <td>2 µm</td> <td>0.1 mm/s</td> </tr> </tbody> </table>	Displacement	Speed	5 µm	0.5 mm/s	2 µm	0.2 mm/s	Displacement	Speed	5 µm	1.0 mm/s	2 µm	0.1 mm/s
Displacement	Speed												
5 µm	0.5 mm/s												
2 µm	0.2 mm/s												
Displacement	Speed												
5 µm	1.0 mm/s												
2 µm	0.1 mm/s												
Non-linearity:	< ± 0.01% full scale (minimum ± 40 µm)												
Repeatability:	< ± 0.001% full scale (minimum ± 2.5 µm) Hysteresis < 4 µm												
Outputs:	Interface: CAN-Fieldbus system ISO DIS 11898 Data protocol CANopen: CIA standard DS-301 V4.02 encoder profile DS-406 V3.1 CANbasic; CAN 2.0 A Baud rate, kBit/s: 1000 800 500 250 125 50 20 Cable length, m: <25 <50 <100 <250 <500 <1000 <2500 The sensor will be supplied with ordered Baud rate which can be changed by the customer.												
Measuring range:	Profile style: 50 to 5080 mm (2 to 200 in.) Rod style: 50 to 7620 mm (2 to 300 in.)												
Operating voltage:	+24 Vdc nominal (-15% or +20%) Polarity protection: up to -30 Vdc Overvoltage protection: up to 36 Vdc Current drain: 100 mA typical Dielectric withstand voltage: 500 Vdc (DC ground to machine ground) Connection type: Single or dual 6-pin male D60 connectors, or integral cable												
Operating temperature:	-40 to +75 °C, (-40 to 167 °F) Relative humidity: 90% no condensation Temperature coefficient <15 ppm/ °C												
EMC test:	Emissions IEC/EN 50081-1, Immunity IEC/EN 50082-2, IEC/EN 61000-4-2/3/4/6, level 3/4 criterion A, CE qualified												
Shock rating:	100 g (single hit)/IEC standard 68-2-27 (survivability)												
Vibration rating:	15 g/10-2000 Hz/IEC standard 68-2-6												
Update time:	1.0 ms up to 2400 mm, 2.0 ms up to 4800 mm, 4.0 ms up to 7600 mm stroke length												

PROFILE STYLE (RP MODEL)

Electronic head:	Aluminum housing Diagnostic display (LED's beside connector/cable exit)
Sealing:	IP 65
Sensor extrusion:	Aluminum (Temposonics profile style)
Mounting:	Adjustable mounting feet or T-slot nut (M5 threads) in base channel
Magnet type:	Captive-sliding magnet or floating (open ring) magnet

ROD STYLE (RH MODEL)

Electronic head:	Aluminum housing Diagnostic display (LEDs beside connector/cable exit)
Sealing:	IP 67 or IP 68 for integral cable model
Sensor rod with flange:	304L Stainless steel
Operating pressure:	350 bar static, 690 bar spike (5000 psi static; 10,000 psi spike)
Mounting:	Threaded flange M18 x 1.5 or 3/4-16 UNF-3A
Typical mounting torque:	45 N-m (33 ft. - lbs.)
Magnet type:	Ring magnet, floating (open ring) magnet, or magnet float

Temposonics CANbus variations

CANopen

CANopen corresponds to encoder profile DS-406 V3.1 (CIA standard DS-301 V4.02). The CANopen functionality is described by the following three communication objects.

- **Service data object (SDO):**

The SDO is mainly used for sensor configuration. Selectable parameters are:

- Resolution for position + speed
- 4 set points
- Preset of the operation range and the null position for four magnets

- **Process data object (PDO):**

The PDO provides real-time data transfer of sensor measurements in up to 8-byte data blocks. The sensor uses PDO's to relay information about magnet position, speed, limit status, cam control and operation range for up to four magnets.

Data formats are: 32-bits for position, 16-bits for speed, and 8-bits for value limit.

- **PDO transmission type:**

Asynchronous (cycle time of 1 to 65.535 ms) or synchronous.

- Synchronization Object (SYNC)
- Emergency Object
- Nodeguard Object

- **CANopen Configuration**

A software file is used as an Electronic Data Sheet (EDS) for sensor configuration. The EDS file is available on the mini CD that is included with the sensor, as well as, on the MTS website, at www.mtssensors.com.

Note:

Conformance Test Certificate No. CiA199902-301V30/I-004 is given by the CANbus user organization CiA (CAN in Automation) for MTS CANopen sensors.

CANbasic (MTS)

CANbasic allows a simple, flexible adaptation to customized profiles with short bus access. The CANbasic protocol complies with CAN 2.0A standard and includes applications data for single-magnet measurement (position, speed, sensor status and five setpoints).

CANbasic (multi-magnet measurement)

CANbasic provides position measurement on a single sensor using a maximum of fifteen magnets. Setup and operation are accomplished through the on-site control system.

CANopen address programmer accessory

The CANopen address programmer is used to setup the Node-Address for sensors with the CANopen interface. This setup is usually completed by the bus' LMT/LSS-Service. If the master system or customer controller does not support this service, connecting the the CANopen Address Programmer to the sensor will bypass the service and allow direct setup. A 24 Vdc power supply connected to the sensor (customer supplied) is required in order to use the programmer.

CANopen address programmer installation

To install and use the CANopen handheld programmer, follow the steps below:

1. Disconnect the bus wiring and power supply.
2. Connect the handheld programmer to the sensor.
3. Connect the power supply to the sensor. The node-address displays.
4. Select a new node-address and apply the new setting by pressing the button.
5. Disconnect the power and programmer.
6. Displaying and programming must be completed in hexadecimal values. Programming is limited to the legal values from 01 to 7F (1 to 127). The factory default is 7F (127).

CANbus programmer (Part No. 252382-D62)

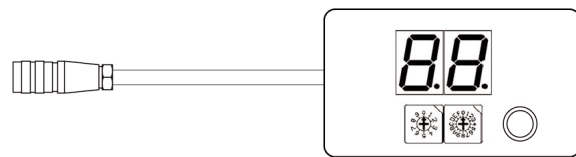

CANbus programmer connections

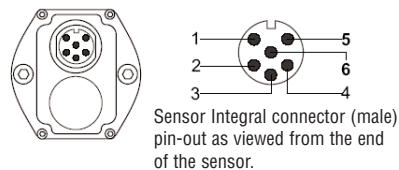
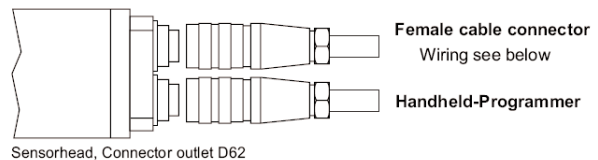

Pin	Function
1	n.c.
2	n.c.
3	n.c.
4	n.c.
5	+24 Vdc
6	DC Ground

Model RP profile-style sensor

Captive-sliding magnet

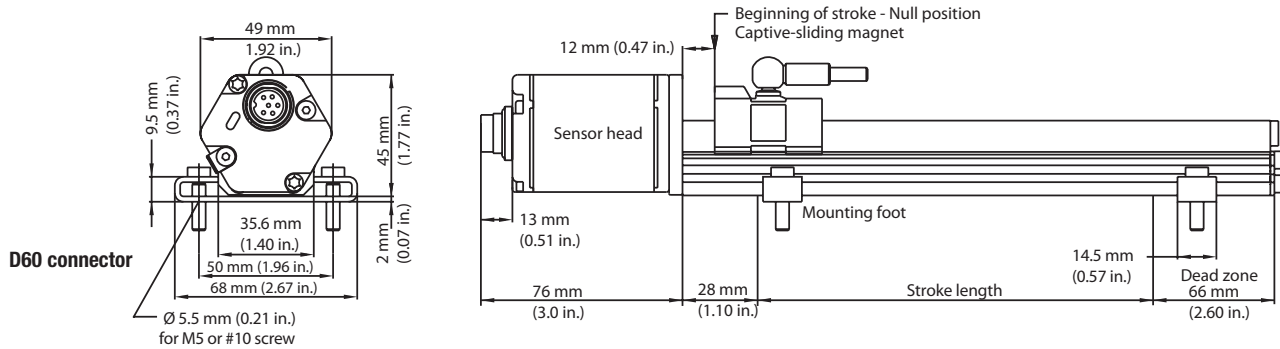

Floating magnet (open ring)

P05 Integral cable option

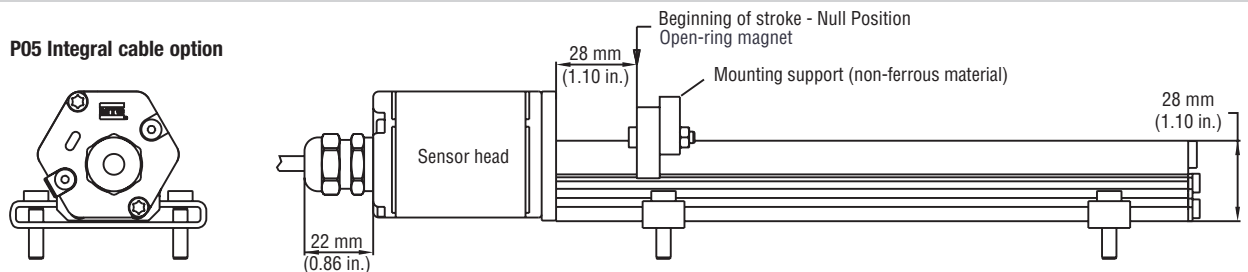

Selection of position magnets (included with sensor)

A choice of two magnet mounting configurations are available with the profile-style sensor; the captive-sliding magnet or the floating (open ring) magnet.

Captive-sliding magnets utilize slide bearings of special material that reduce friction, and if required, help mitigate dirt build up. The slide bearings are designed to operate dry, requiring no external lubrication or maintenance.

The floating magnet (open ring) mounts on the moving machine part and travels just above the sensor's profile extrusion. The open ring magnet (style M) requires a minimum distance away from ferrous metals to allow proper sensor output. It must be mounted using non-ferrous screws and a non-ferrous support bracket, or utilize a non-ferrous spacer of at least 5 mm (0.2 in.) thickness.

Captive-sliding magnet, style S part no. 252182

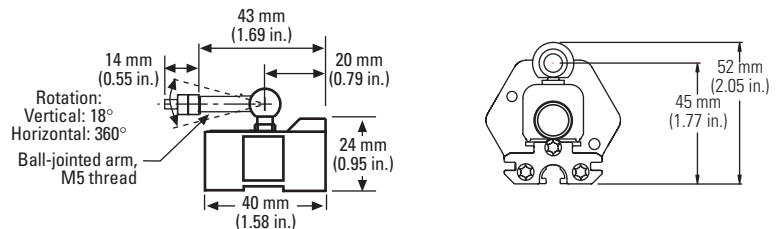

Captive-sliding magnet, style V part no. 252184

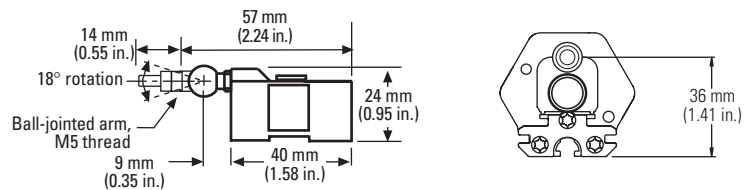

Floating (open ring) magnet, style M part no. 251416-2

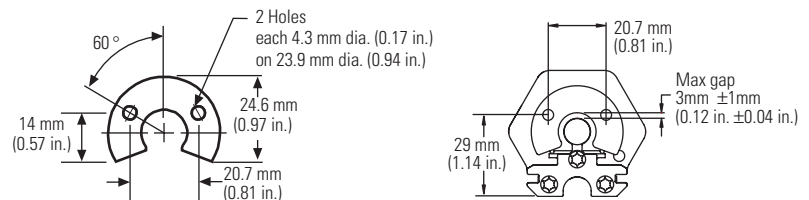

ID: 13.5 mm (0.53 in.)
OD: 32.8 mm (1.29 in.)
Thickness: 7.9 mm (0.312 in.)

Model RH rod-style sensor

The Temposonics R-Series rod-style sensor (Model RH) offers modular construction, flexible mounting configurations, and easy installation. It is designed for internal mounting in applications where high pressure conditions exist, (5000 psi continuous, 10,000 psi spike), such as hydraulic cylinders. The Model RH sensor may also be mounted externally in many applications.

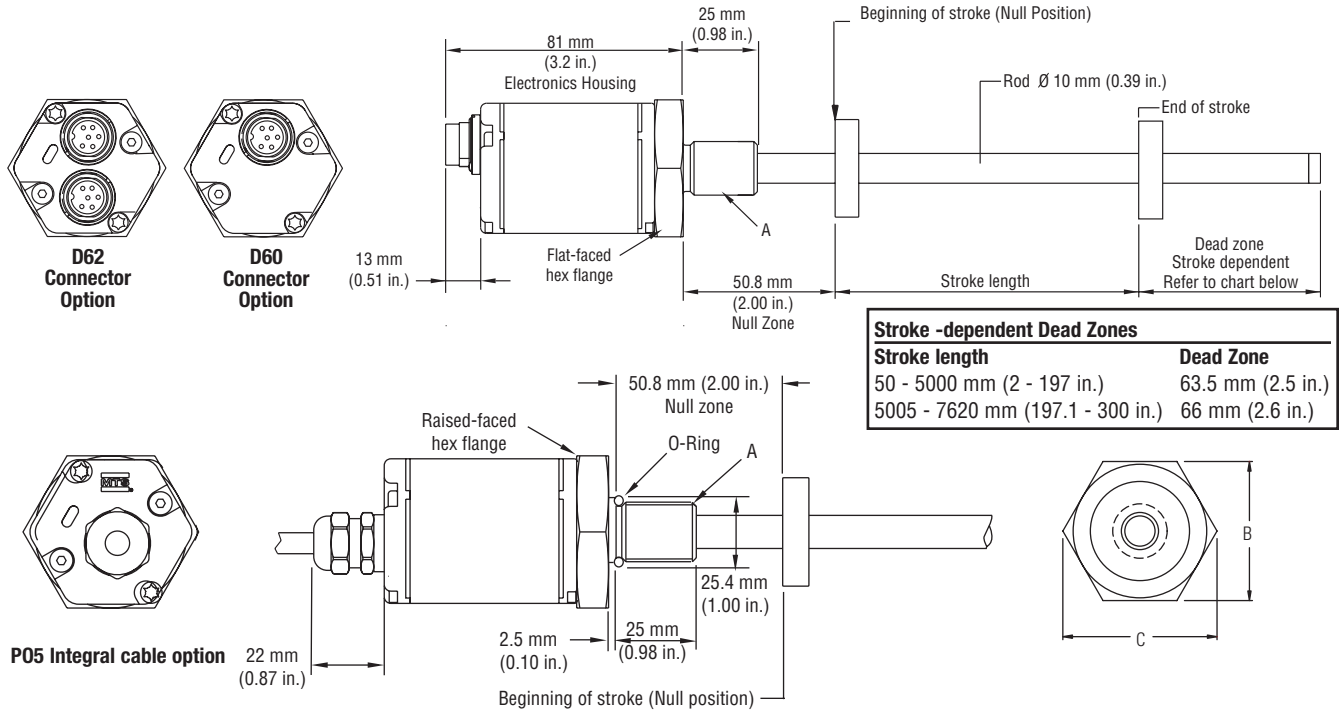

Housing style Flange type	Description	A Flange threads	B Dimensions	C Dimensions
T	US customary threads with raised-face hex	3/4"-16 UNF-3A	44.5 mm (1.75 in.)	51 mm (2.0 in.)
S	US customary threads with flat-faced hex	3/4"-16 UNF-3A	44.5 mm (1.75 in.)	51 mm (2.0 in.)
M	Metric threads with flat-faced hex	M18 x 1.5	46 mm (1.81 in.)	53 mm (2.1 in.)

Selection of position magnets (must order separately)

Magnets must be ordered separately with model RH position sensors. The standard ring magnet (part number 201542-2) is suitable for most applications.

Magnet Float (Level Sensing Application) Part No. 251447

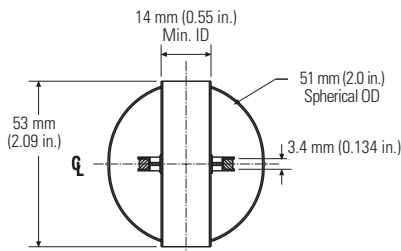

Specific Gravity: 0.70 max.
Pressure: 870 psi max.
(Float for use with rod-style sensors in hydraulic fluid or fresh water applications only)

Standard-ring magnet part no. 201542-2

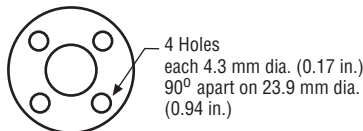

ID: 13.5 mm (0.53 in.)
OD: 32.8 mm (1.29 in.)
Thickness: 7.9 mm (0.312 in.)

Ring magnet part no. 400533



ID: 13.5 mm (0.53 in.)
O.D.: 25.4 mm (1.0 in.)
Thickness: 7.9 mm (0.312 in.)

Floating (open ring) magnet, style M part no. 251416-2

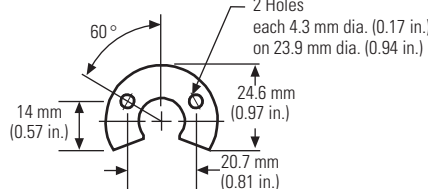

ID: 13.5 mm (0.53 in.)
OD: 32.8 mm (1.29 in.)
Thickness: 7.9 mm (0.312 in.)

Magnet spacer (non-ferrous spacer for use with standard ring magnet) part no. 400633



ID: 14.3 mm (0.56 in.)
O.D.: 31.8 mm (1.25 in.)
Thickness: 3.2 mm (0.125 in.)

Mounting, wiring and magnets

Profile-style sensor mounting

Flexible installation in any position

Temposonics model RP profile-style sensors offer two basic mounting methods, side grooves for use with mounting feet or a bottom groove that accepts special T-slot nuts. Both the mounting feet and T-slot nuts can be positioned along the sensor extrusion to best secure the sensor for each particular application.

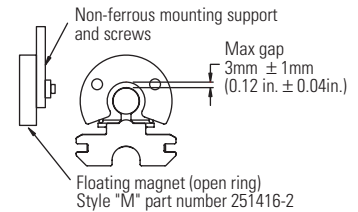
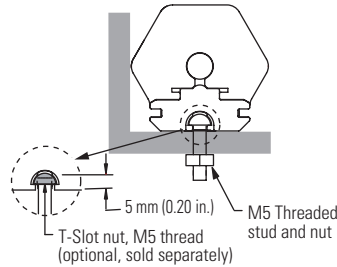
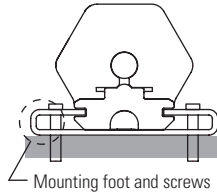

Note:

Temposonics Model RP sensors include two mounting feet (part no. 400802) for sensors up to 1250 mm (50 in.) One additional mounting foot is included for every additional 500 mm (20 in.)

Rod-style sensor mounting

The position magnet requires minimum distances away from ferrous metals to allow proper sensor output. The minimum distance from the front of the magnet to the cylinder end cap is 15 mm (0.6 in.). The minimum distance from the back of the magnet to the piston head is provided by the non-ferrous spacer, i.e. 3.2 mm (0.125 in.).

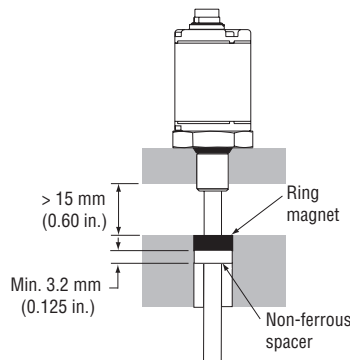

Sensor integral connector (for single D60 and for dual D62)

Male Integral D6 connector pin-out as viewed from end of the sensor



Pin no.	Wire color	Function
1	Gray	CAN (-)
2	Pink	CAN (+)
3	Yellow	n.c.
4	Green	n.c.
5	Red or Brown	+24 Vdc (-15 / + 20%)
6	White	DC Ground (for supply)

Cylinder installation

When used for direct stroke measurement in fluid cylinders, the sensor's stainless steel rod installs into a bore in the piston head/rod assembly as illustrated. This method guarantees a long life and trouble-free operation.

The sensor cartridge can be removed from the flange and rod housing while still installed in the cylinder. This procedure allows quick and easy sensor cartridge replacement, without the loss of hydraulic pressure.

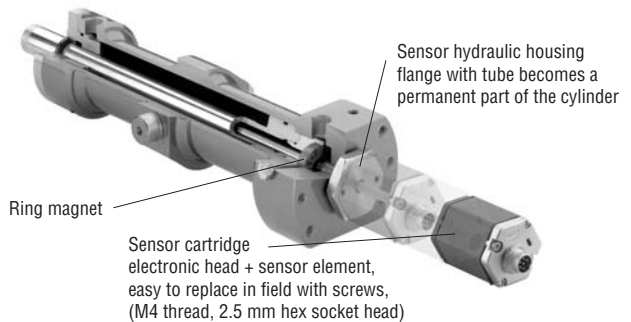

Cable connectors (field installed D6 female)

D6 straight-exit connector (PG9 size strain relief for 8 mm max. cable dia.) part no. 370423

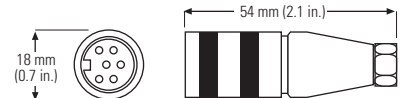

D6 90° connector part no. 560778

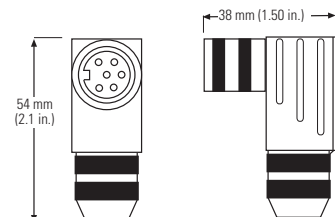

How to order

1	2	3	4	5	6	7	8	9	10	11	12	13	14	15	16	17	18	19
R											1	C						

SENSOR MODEL

RP = Profile style
RH = Hydraulic rod style

HOUSING STYLE

Temposonics model RP profile-style sensor only (magnet included):
S = Captive-sliding magnet with joint at top (part no. 252182)
V = Captive-sliding magnet with joint at front (part no. 252184)
M = Floating magnet, open ring (part no. 251416-2)

Temposonics model RH rod-style sensor only
(magnet must be ordered separately):
T = US customary threads, raised-faced hex, and pressure tube
S = US customary threads, flat-faced hex, and pressure tube

M = Metric threads, flat-faced hex, and pressure tube
B = Sensor cartridge only (No pressure tube, stroke lengths ≤ 72 in.).

STROKE LENGTH

--- **M** = Millimeters (Encode in 5 mm increments)
- - - **U** = Inches and tenths (Encode in 0.1 in. increments)

CONNECTION TYPE

Integral connector
D60 = single 6 pin DIN, Integral, standard
D62 = Dual 6 pin DIN, Integral

Integral cable
P = PUR Integral cable with pigtail termination, standard.

Cable length options:
- - - = Encode in feet if using US customary stroke length, encode in meters if using metric stroke length
Range = 1 (01) to 99 (99) ft. or 1 (01) to 30 (30) meters.

INPUT VOLTAGE

1 = +24 Vdc (+20%, -15%)

OUTPUT

C - - - - - = CANbus output (fill in the six blanks with the following codes)
a b c d e f

a, b, c = CANbus hardware and protocol code:	d = Baud rate:	e = Resolution:	f = Cycle time:
101 = Single magnet - CANbasic (MTS)	1 = 1000 kBit/s	1 = 0.0002 in. (0.005 mm)	1 = Standard
207 = Multi-magnet	2 = 500 kBit/s	2 = 0.00008 in. (0.002 mm)	
304 = CANopen	3 = 250 kBit/s		
	4 = 125 kBit/s		

Stroke length notes:

- Profile (RP) stroke range = 50 - 5080 mm (2 - 200 in.)
- Rod (RH) stroke range = 50 - 7620 mm (2 - 300 in.)

Cable length notes:

- MTS recommends the maximum integral cable length to be 10 meters or 33 feet.
- Cables greater than 10 meters in length are available, however, proper care must be taken during handling and installation. Contact factory for cable length limitations.

Specify number of magnets utilized at time of order. More than 15 magnets requires application engineering approval
CANbus EDS files are available on the Temposonics website at www.mtssensors.com.

How to order (continued)

Accessories

Description	Function/Notes	Part no.
Mounting feet, standard (spares)	Model RP sensors come with mounting feet (see page 6).	400802
Base channel T-slot nut	Nut for mounting model RP sensors. Requires M5 screw (see page 6).	401602
O-Ring (spare)	For use with model RH sensors with style "T" or "S" housing	560315
O-Ring (spare)	For use with model RH sensors with style "M" housing	401133
Joint-rod Sleeve (1 in.)	For use with model RP sensors with "S" or "V" style magnets	401603
Ball-jointed arm, straight	For use with model RP sensors with "S" or "V" style magnets	401913

Magnets and float options

Description	Function/Notes	Part no.
Small open ring (model RP spare)	Magnet style M, "floating" magnet used with model RH and RP sensors.	251416-2
Small ring magnet	Standard magnet for model RH sensors.	201542-2
Magnet float	For use with RH sensors used to measure liquid level.	251447
Captive-sliding magnet (spare)	Style S captive-sliding magnet with joint at top. Comes with RP sensors.	252182
Captive-sliding magnet (spare)	Style V captive-sliding magnet with joint at front. Comes with RP sensors.	252184
Magnet spacer	For use with standard ring magnet, part no. 201542-2.	400633
Collar	Provides end of stroke "stops" for magnet float, part no. 251447.	560777
Magnet mounting screws	Used to mount the standard ring magnet, part no. 201542-2. (4 screws required)	560357

Field-installed connectors

Description	Function/Notes	Part no.
6-Pin DIN connector, straight	Female, straight exit, mates to D60 and D62 connection types. See page 6.	370423
6-Pin DIN connector, 90°	Female, 90° exit, mates to D60 and D62 connection types. See page 6.	560778

Cables

Description	Function/Notes	Part no.
PUR cable	High performance shielding, orange polyurethane jacket.	530029

Programming tool

Description	Function/Notes	Part no.
CANopen Address Programmer	Set up node address	252382 -D62
Tool		

Optional extension rods (for use with captive-sliding magnets)

Extension rod lengths	Part no.	Extension rod lengths	Part no.
60.3 mm (2.375 in.)	401768-2	390.5 mm (15.375 in.)	401768-15
85.7 mm (3.375 in.)	401768-3	466.7 mm (18.375 in.)	401768-18
111.1 mm (4.375 in.)	401768-4	517.5 mm (20.375 in.)	401768-20
161.9 mm (6.375 in.)	401768-6	542.9 mm (21.375 in.)	401768-21
187.3 mm (7.375 in.)	401768-7	619.1 mm (24.375 in.)	401768-24
212.7 mm (8.375 in.)	401768-8	771.5 mm (30.375 in.)	401768-30
238.1 mm (9.375 in.)	401768-9	923.9 mm (36.375 in.)	401768-36
263.5 mm (10.375 in.)	401768-10	1076.3 mm (42.375 in.)	401768-42
314.3 mm (12.375 in.)	401768-12	1228.7 mm (48.375 in.)	401768-48
365.1 mm (14.375 in.)	401768-14	1533.5 mm (60.375 in.)	401768-60

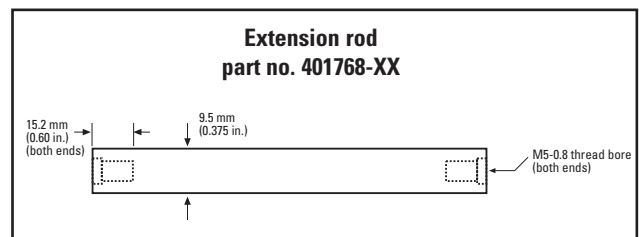
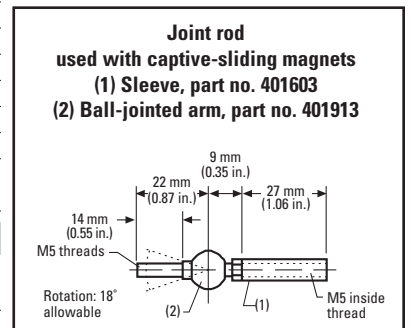
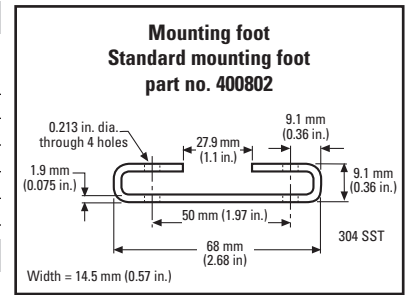

Part Number: 05-06 550991 Revision B

Temposonics and MTS are registered trademarks of MTS Systems Corporation.
All other trademarks are the property of their respective owners.
All Temposonics sensors are covered by US patent number 5,545,984. Additional patents are pending.
Printed in USA. Copyright © 2006 MTS Systems Corporation. All Rights Reserved.

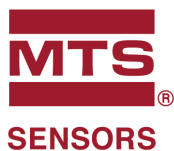

UNITED STATES
MTS Systems Corporation
 Sensors Division
 3001 Sheldon Drive
 Cary, NC 27513
 Tel: (800) 633-7609
 Fax: (919) 677-0200
 (800) 498-4442
 www.mtssensors.com
 sensorsinfo@mts.com

GERMANY
MTS Sensor Technologie
 GmbH & Co. KG
 Auf dem Schuffel 9
 D-58513 Lüdenscheid
 Tel: +49 / 23 51 / 95 87-0
 Fax: +49 / 23 51 / 56 491
 www.mtssensor.de
 info@mtssensor.de

JAPAN
MTS Sensors Technology
 Corporation
 Ushikubo Bldg.
 737 Aihara-cho, Machida-shi
 Tokyo 194-0211, Japan
 Tel: + 81 (42) 775 / 3838
 Fax: + 81 (42) 775 / 5516
 www.mtssensor.co.jp
 info@mtssensor.co.jp