

Cast-In Heaters



“L” Shaped

“L” Shaped Bronze, Brass or Aluminum Cast-In Heaters for Square and Rectangular Extruder Barrels



Cast-In Heaters that provide High Temperature and Maximum Processing Capabilities

The “L” Shaped Cast-In Heaters are typically used on square and rectangular twin screw extruder barrels in compounding and plastic resin manufacturing applications. Due to high shear rates, which are common in this process, extreme operating temperatures and high watt densities are frequently encountered. For these reasons Tempco manufactures “L” shaped heaters in bronze or brass alloys, which are capable of withstanding high temperatures at higher watt densities.

In the case of applications requiring lower temperatures and lower watt densities, aluminum alloys can be used. Aluminum castings are desirable as they have greater thermal conductivity and weigh substantially less than their bronze or brass counterparts, allowing for greater ease of installation.

For mounting purposes, the heaters can be designed with 45° flanged ear extensions that are bolted and drawn together, or can be made with through holes machined into the casting body to bolt directly onto the barrel itself. Thermocouple and transducer holes or other special features can be accommodated as well.

To enhance the cooling capabilities, or to be used in place of integral feed screw cooling, “L” shaped heaters can be manufactured with cast-in cooling tubes to satisfy liquid cooling requirements. This feature allows processors the ease of changing a single unit at a time, thus representing a far less time-consuming and less expensive alternative should a cooling line become clogged or severely restricted.

Standard “L” Shaped Cast-In Heaters Design Features

- * *Cast-In Bronze or Brass Alloys for high temperature, high shear applications*
- * *Manufactured in sets consisting of two corresponding halves*
- * *Flange bolt clamping arrangement or through holes in the heater body, allowing bolt mounting directly to the barrel*
- * *High precision machining of the inner contact surface of the heater, yielding exceptional heat transfer to the process*
- * *Moisture resistant terminal housing which is available in a variety of different styles and mounting arrangements*
- * *Choice of terminal protection housings*
- * *Elevated temperature terminations and enclosures. Prevents premature heater failure due to accelerated corrosion or oxidation of terminals caused by high heater surface temperature. See page 3-64 and 3-65 for details on how to order.*

Enhanced Features

To aid processors in reducing maintenance downtime, Tempco has introduced several optional construction features to the basic “L” shaped design.

- * *Cast-In Aluminum Alloys for applications requiring lower temperatures and less watt density*
- * *3/8" or 1/2" O.D. cooling tubes for liquid cooling*
- * *Non-Exposed cooling tubes (Type RC—See page 3-49). Eliminates cracked and broken cooling tubes.*



Note: All of the options listed above are design enhancements that will provide value-added benefits to the basic “L” shape configuration, thereby extending the life and performance of your Cast-In Heaters.



Standard (Non-Stock) "L" Shaped Cast-In Heaters

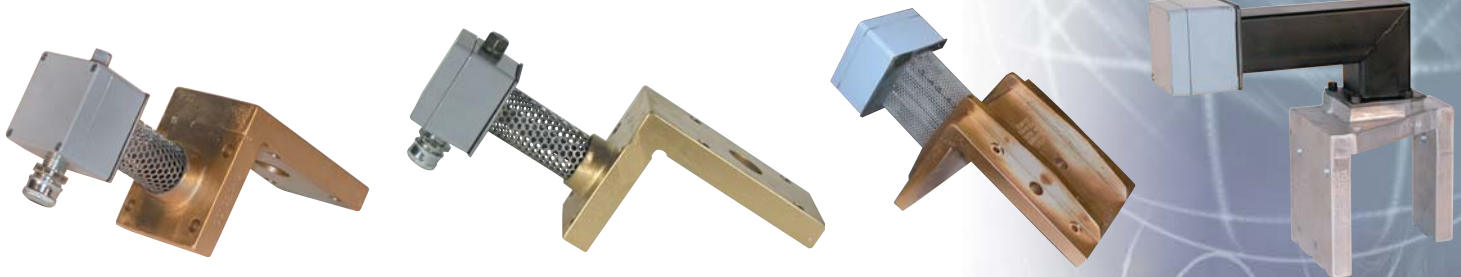

"L" Shaped Bronze, Brass or Aluminum Cast-In Heaters

are sold as sets or as individual units. They are normally supplied with a moisture resistant junction box. Also available with explosion resistant or cast-on junction box, fitted with convoluted wire braided hose and high temperature lead wire. If required, specify. For additional terminations, see pages 3-52 and 3-53.

The sizes and ratings listed are among the most commonly used. They will provide the shortest lead times.

Long Leg (in)	Short Leg (in)	Width in	Thickness in	Watts	Volts	Special Features	Part Number
3.500	2.500	3.500	0.875	500	240	Cast terminal box, (3) .397" dia. holes, (1) 1/8" dia. cutout, Bronze	CBH05817
3.500	2.500	3.500	0.875	500	240	Cast terminal box, (3) .397" dia. holes, Bronze	CBH05818
3.500	2.500	7.000	0.875	1000	240	Cast terminal box, (6) .397" dia. holes, Bronze	CBH05819
2.500	1.550	1.750	0.500	300	120	(1) 1/2" long slot, R1, Hubbel® plug, Aluminum	CBH04036
2.500	1.550	1.750	0.500	300	120	(1) 1/8" NPT hole, (1) 1/2" long slot, Bronze	CBH04103
3.460	2.680	4.330	1.181	500	220	MPR terminal box, (1) 25 mm dia. hole, (4) 9 mm dia. holes, Aluminum	CBH04926
3.460	2.680	4.330	1.181	500	220	MPR terminal box, (1) 25 mm dia. hole, (4) 9 mm dia. holes, Aluminum	CBH04922
3.460	2.760	4.330	1.181	500	220	MPR terminal, (1) 25 mm dia. hole, (8) 9 mm dia. holes, Aluminum	CBH04929
3.937	3.465	4.331	1.181	500	230	MPR terminal, 3/8" NPT RA elbow C/T, Brass	CBH04045
4.173	3.071	4.310	1.000	900	240	Cast terminal box, (2) 1/2" dia. holes, (2) 1/2" dia. cutouts, Bronze	CBH01617
4.173	3.346	4.921	1.575	2000	230	MPR, (1) 25 mm dia. hole, Brass	CBH04295
4.724	3.248	4.921	1.575	1500	230	MPR terminal box, (1) 25 mm dia. hole, Brass	CBH04290
4.823	3.346	4.921	1.575	2000	230	MPR terminal box, (1) 25 mm dia. hole, Brass	CBH04294
6.000	4.449	6.417	1.000	2000	240	Cast terminal box, (4) 1/2" dia. holes, (2) 1" long cutouts, Bronze	CBH01618
6.140	4.311	7.480	0.750	2500	240	Cast terminal box, (5) 1/2" dia. holes, (2) 1/2" dia. cutouts, Bronze	CBH01971
6.180	4.215	6.690	1.000	3000	240	Cast terminal box, (5) 1/16" dia. holes, (2) 1" dia. cutouts, Bronze	CBH02140
6.188	4.313	1.000	1.000	1500	240	Cast terminal box, (1) 1" dia. hole, (4) 1/4" dia. holes, Bronze	CBH01619
7.756	11.693	14.961	1.970	4500	460	MPR terminal box, (6) .394" dia. holes, Aluminum	CBH05011
7.813	5.188	10.625	1.000	5250	480	Cast terminal box, (8) 1/16" dia. holes, Bronze	CBH03042
7.830	5.220	10.63	0.980	3500	480	Cast terminal box, (8) 1/16" dia. holes, Bronze	CBH02114
7.874	6.102	10.394	1.000	4200	480	Cast terminal box, (6) 1/16" dia. holes, Bronze	CBH01692
7.874	6.102	10.394	1.000	4200	480	Cast terminal box, (6) 1/16" dia. holes, Bronze	CBH01839
8.500	6.140	2.750	0.750	1200	240	Cast terminal cover, (1) 1" dia. hole, (2) 1/2" dia. holes, Bronze	CBH01725
8.500	6.140	7.480	0.750	5250	240	Cast terminal box, (6) 1/2" dia. holes, (2) 3/8" dia. holes, Bronze	CBH02124
8.890	5.945	6.420	1.000	3000	240	Cast terminal box, (6) 1/2" dia. holes, (1) 1" dia. hole, Bronze	CBH01550
9.055	4.684	2.362	0.591	750	240	13" Cable, 18" leads, (5) .413" dia. holes, Aluminum	CBH04591
9.134	6.000	7.480	1.000	3500	240	Cast terminal box, (4) 1/2" dia. holes, Bronze	CBH05352
9.173	6.181	10.630	1.772	5000	230	MPR terminal box, (8) .472" dia. holes, (1) 1" dia. hole, Brass	CBH03940
9.449	7.756	14.330	1.102	6800	277	Cast terminal box, 3 phase, (8) 1/16" dia. holes, Bronze	CBH01667
9.449	7.756	14.330	1.102	6800	575	Cast terminal box, 3 phase, (4) 1/2" dia. holes, (4) 1/16" dia. holes, Bronze	CBH01709
10.563	7.813	10.625	1.000	8800	480	Cast terminal box, 3 phase, (8) 1/16" dia. holes, Bronze	CBH03041
10.590	7.830	10.630	1.000	5500	480	Cast terminal box, 3 phase, (8) 1/16" dia. holes, Bronze	CBH02113
10.830	4.684	2.362	0.591	870	240	MPR terminal box, (5) .413" dia. holes, Aluminum	CBH04594
11.690	7.756	14.960	1.969	9000	460	MPR term. box, (8) .393" & (1) .984" dia holes, Al., Heat & Cool	CBH05012
11.690	7.756	14.960	1.968	N/A	N/A	(12) .393" dia. holes, (1) .984" dia. hole, Aluminum	CBH05013
11.690	7.760	14.960	1.969	9000	460	MPR terminal box, (10) .393" dia. holes, Aluminum	CBH05014
12.188	7.875	10.375	1.000	8100	480	Cast terminal box, (6) 1/16" dia. holes, Bronze	CBH04408
12.205	7.875	4.134	1.000	3000	240	Cast terminal box, (4) 1/16" dia. holes, (1) 1/8" dia. cutout, Bronze	CBH01756
12.205	7.875	10.394	1.000	6260	480	Cast terminal box, (6) 1/16" dia. holes, Bronze	CBH02144
15.712	13.000	9.250	1.250	5500	220	(6) 1/2" dia. holes, (1) 1/8" hole, Bronze	CBH05037
18.110	9.169	4.530	0.591	3030	240	(10) .493" dia. holes, 20" cable, 27" leads, Aluminum	CBH04593
18.110	9.169	4.530	0.591	3030	240	MPR terminal box, (10) .430" dia. holes, Aluminum	CBH04596

Key for Abbreviations found under the Features Column

E/H = Each Half	C/T = Cooling Tubes
EP = Explosion Resistant Terminal Housing	CW = Single Set of Cooling Tubes
MR = Moisture Resistant Terminal Housing	CWW = Dual Set of Cooling Tubes
MPR = Moisture Proof Die Cast Aluminum Box	RC = Non-Exposed Cooling Tubes/Recessed NPT Fittings



Ordering Information

"L" Shaped Cast-In Heater – 45° Flange Mount Style Ordering Information

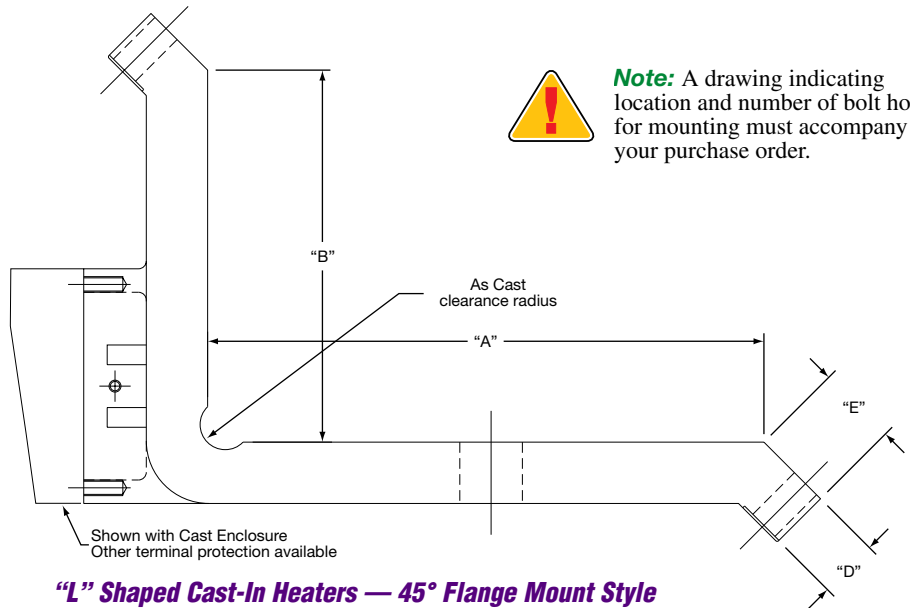
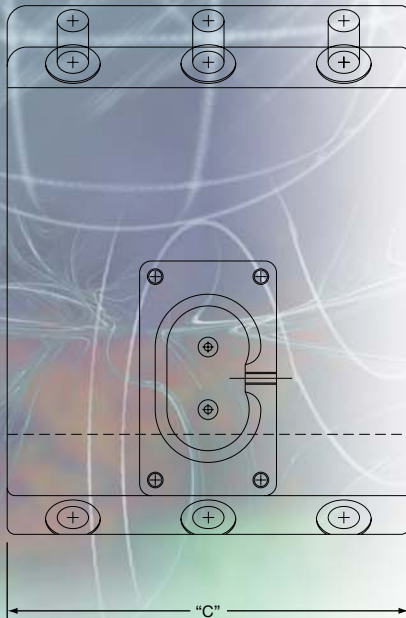

"L" Shaped Cast-In Heaters — 45° Flange Mount Style

Variable Dimensions "A" _____ "B" _____ "C" _____
 "D" _____ "E" _____

Ordering Information

To process your order or quotation,
please specify the following information.

Material Specifications Aluminum Bronze Brass

Electrical Specifications Watts each piece _____ Volts each piece _____ Phase _____

Clamping Style Bolt Clamp Other

Cooling Tube Sizes 1/4" O.D. SS 3/8" O.D. SS 1/2" O.D. SS Optional Incoloy® (1/2" only)
 Dual Cooling Tubes

Cooling Tube Fittings Non-exposed 3/8" NPTF "HS" Hi-Seal Fitting "RA" 90° Copper Elbow
 Non-exposed 1/2" NPTF "BF" High Pressure "RT" 90° Threaded Elbow
 "FF" Flared Seal "R3" Straight Threaded

Termination Style "S" Post Terminals "T7" Post Terminals "T" Post Terminals
 "R1" Armor Cable Leads "E" Right Angle Lugs

Terminal Protection Box "C2" Standard Cast on box as shown
 "EP" Explosion Resistant "MR1" Rigid Moisture Resistant Box
 "MPR" Moisture Resistant Box "P2" High Temperature Quick Disconnect
 "CB1" Cast Aluminum Box

Surface Finish Machined or As Cast. *Indicate surfaces to be machined.*

Special Cast-In Features Holes, Cutouts, Slots, Bevels, Mounting Studs, Stand-Offs and Taper Angles.
For special features a detailed drawing is required.



"L" Shaped Cast-In Heaters Bolt Direct to Barrel Style Ordering Information

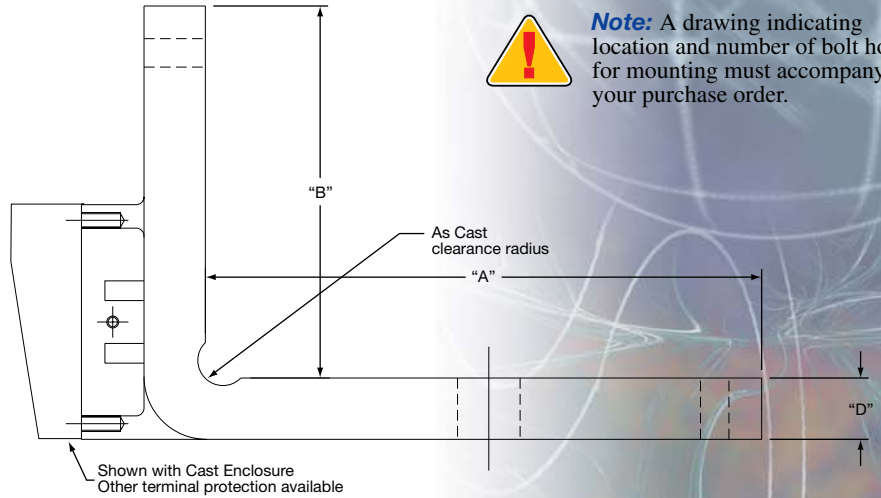
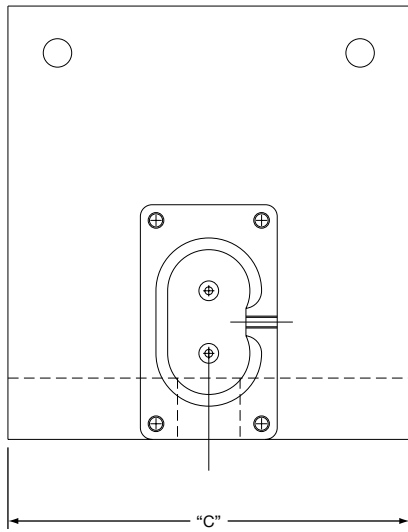

"L" Shaped Cast-In Heaters Bolt Direct to Barrel Style

Variable Dimensions

"A" _____ "B" _____ "C" _____
"D" _____

Ordering Information

To process your order or quotation, please specify the following information.

Material Specifications

Aluminum Bronze Brass

Electrical Specifications

Watts each piece _____ Volts each piece _____ Phase _____

Clamping Style

Bolt Clamp Other

Cooling Tube Sizes

1/4" O.D. SS 3/8" O.D. SS 1/2" O.D. SS
 Optional Incoloy® (1/2" only) Dual Cooling Tubes

Cooling Tube Fittings

Non-exposed 3/8" NPTF "HS" Hi-Seal Fitting "RA" 90° Copper Elbow
 Non-exposed 1/2" NPTF "BF" High Pressure "RT" 90° Threaded Elbow
 "FF" Flared Seal "R3" Straight Threaded

Termination Style

"S" Post Terminals "T7" Post Terminals "T" Mica Washers
 "R1" Armor Cable Leads "E" Right-Angle Lugs

Terminal Protection Box

"C2" Standard Cast on box as shown
 "EP" Explosion Resistant "MR1" Rigid Moisture Resistant Box
 "MPR" Moisture Resistant Box "P2" High Temperature Quick Disconnect
 "CB1" Cast Aluminum Box

Surface Finish

Machined or As Cast. *Indicate surfaces to be machined.*

Special Cast-In Features

Holes, Cutouts, Slots, Bevels, Mounting Studs, Stand-Offs and Taper Angles.
For special features a detailed drawing is required.