

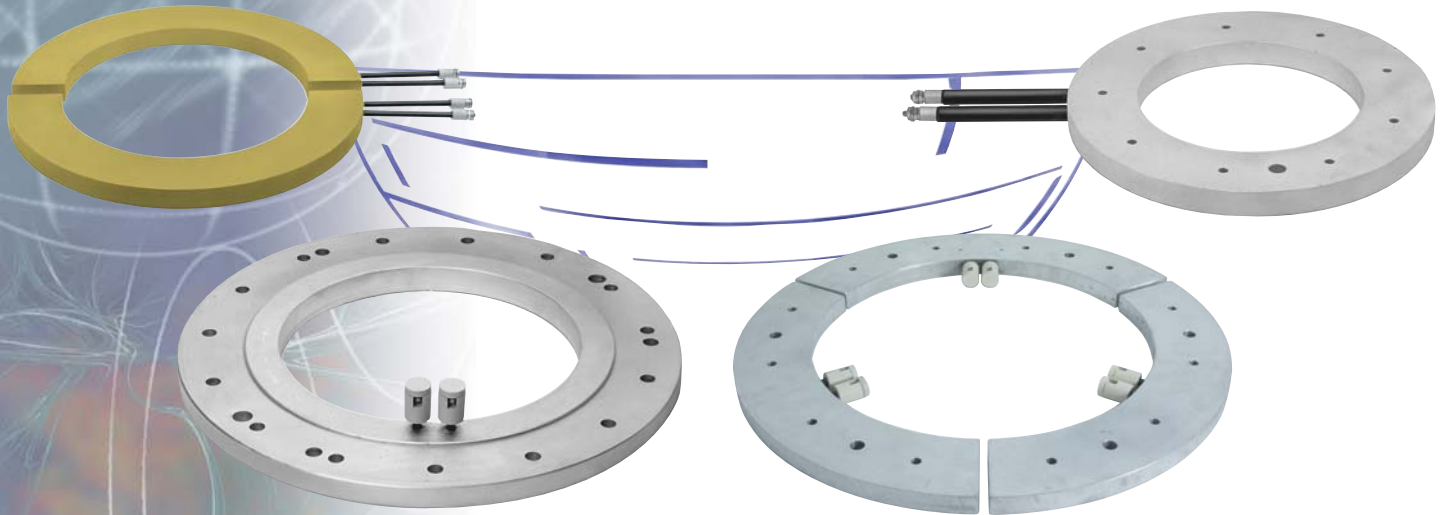

## Ring Shaped

### Cast-In Aluminum or Bronze Ring Heaters for Plastics Processing Equipment



#### Designed to Heat Limited Access Locations

Tempco Cast-In Ring Heaters provide an excellent means of applying extremely uniform heat to limited access application areas. Cast-In Ring Heaters are frequently used in Blown Film Die, Extrusions Die, Screen Changer and Extruder Barrel Adapter applications where long life and minimal maintenance concerns are prevalent.

The design scope of this product line makes it possible to cast large or small diameter disc shaped rings with nominal thicknesses of 5/8" to 1". These units are an excellent choice for heating the top or bottom of a cylindrical die.

As a standard, Cast-In Ring Heaters are generally manufactured in aluminum because of its superior thermal conductivity. For higher temperature or high watt density requirements, bronze or brass alloys can be used. A variety of standard terminations shown on pages 3-52 and 3-53 are available. The units can be fully machined to include through holes for mounting, thermocouple holes and surface machining.

#### Standard Cast-In Ring Heaters

##### Design Features and Options

- \* Computer designed, precisely formed tubular heating element optimizing the heat transfer pattern
- \* Variety of termination options including terminal enclosure housings
- \* Optional 1/4", 3/8" or 1/2" cooling tubes cast into the ring body for liquid cool function
- \* Variety of shapes and sizes
- \* Through holes, tap holes or cutouts to facilitate mounting or obstructions
- \* Precision machining of one or all surfaces of casting – specify your individual requirements.

#### CUSTOM Manufactured

For sizes and ratings not listed, **TEMPCO** will design and manufacture a Cast-In Ring Heater to meet your requirements.

##### Specify the following:

- Inside Diameter
- Outside Diameter
- Thickness
- Wattage and Voltage
- Termination Type (see pages 3-52 and 3-53)
- Alloy (Aluminum or Bronze)
- Special Features
- Machining Specifications
- Detailed Drawing

#### Stock and Standard (Non-Stock) Cast-In Ring Heaters

I.D. in	O.D. in	Thickness in	Watts	Volts	Special Features	Part Number
5.500	14.000	1.000	2250	230	(8) 3/32" dia. holes	CBH02625
6.750	11.750	1.000	1250	480	(4) 1/16" dia. holes E/H	CBH05499
7.000	11.500	0.875	3200	240	(9) 3/32" dia. holes	*CBH01084
7.000	11.500	0.875	3200	460	(9) 3/16" dia. holes, (1) 1/2" dia. hole	CBH05415
8.500	13.000	1.000	3000	230	(8) 3/32" dia. holes	CBH01101
10.000	14.500	0.875	4000	230	(8) 3/32" dia. hole, (8) 1 1/32" c'bore	*CBH01196
10.000	14.500	0.875	1000	230		*CBH01085
12.000	16.250	0.875	2125	230	Bronze	*CBH01261
12.000	16.250	0.875	2125	230	Bronze	CBH04776
13.000	20.000	1.120	2025	460	(4) 1/16" dia. holes E/H, (2) 1/2"-13 taps	CBH04836
16.250	20.500	1.000	1500	480	(6) 1/16" dia. holes	CBH04943
17.000	20.000	1.500	1250	230	(4) 90° Segments	CBH04990
19.750	34.000	1.130	4000	460	(12) 1/16" dia. holes, (2) 1/2"-13 taps	CBH04837
23.000	29.000	1.000	2000	480	(8) 1 1/32" dia. holes, (1) 1/8" dia. hole	CBH04220
32.500	40.000	1.125	9000	460	(24) 3/8" dia. holes	CBH02235
43.250	56.250	1.125	4333	290	(16) 1/16" dia. holes	CBH02811

An asterisk (\*) next to the Part Number guarantees in-stock availability for same-day shipping when

**ORDERED BY 2 PM CST**



**Note:** Part numbers are for aluminum heaters unless otherwise specified.